HYDRAULIC COMPONENTS CATALOG



Garlock
SEALING TECHNOLOGIES®

Experience... Technology... Products

Garlock has been the leading manufacturer of industrial sealing products for over 114 years. The Hydraulic Components division has the experience, technology and products to meet the demanding needs found in today's reciprocating equipment.

- **CHEVRON®**: the original vee ring packing, now available in Deep Vee Ring design
- **Style 8380 LOCK-PACK™**: nonadjustable plunger pump packing
- **Style 9220 GARTHANE® U-Seals**: strong, flexible, and durable
- **Polytop and SLUDGE-PAK® Sets**: unique combinations for difficult service
- **Roll Balance Packing**: tough steel and aluminum mill packing
- **Style 9003 Wear Rings**: made from MARBLOCK® for heavy duty service
- **Piston Cups**: wide range of standard materials
- **Model 79 Rod Scrapers**: GARTHANE® lip and steel case set the standard

Contents

CHEVRON® Vee Ring Packing	Inside cover
Applications	1
Product Selection Data Sheet	1
Recommended Styles for General Service	2
CHEVRON® Stack Height Table	4
Vee Ring and Adapter Designs	5
Design Parameters	6
Clearances	6
Deep Vee CHEVRON® Packing	7
CHEVRON® Packings for High Pressure Service	7
Seals for Reciprocating Plunger Pump Applications	8
CHEVRON® Installation and Adjustment	9
Other Styles	
Style 8380 LOCK-PACK™	9
Style 9220 GARTHANE® U-Seals	10
Polytop Sets	11
SLUDGE-PAK® Sets	11
Roll Balance Packing	12
Style 9003 MARBLOCK® Wear Rings	12
Piston Cups	12
Model 79 Rod Scrapers	13

CHEVRON® Packing

Automatic sealing system

Garlock CHEVRON® packing is the original automatic hydraulic and pneumatic design for sealing rods, pistons and plungers. The distinctive and exclusive hinge-like action of each CHEVRON® ring permits immediate reaction even to minor pressure changes. Each individual lip of a CHEVRON® packing set independently reacts to pressure, and automatically effects a seal. The multiple lip configuration automatically distributes pressure and an effective seal along the shaft. The proprietary design of Garlock CHEVRON® packing also permits an automatic reaction to pressure shock and overloads. Once Garlock CHEVRON® packing has been selected and installed, it will seal effectively... and automatically.

Made in the U.S.A.

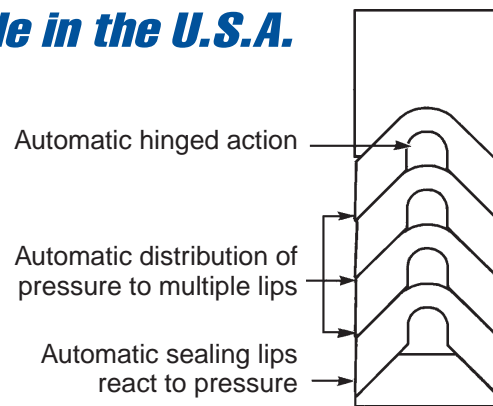

Features

Advantages

Multiple sealing lips	<ul style="list-style-type: none"> ■ Automatically distribute system pressure ■ Offers "back-up" sealing rings
Hinged design	<ul style="list-style-type: none"> ■ Vee rings automatically react to increasing/decreasing pressure ■ Makes rings easy to install
Wide range of materials and sizes	<ul style="list-style-type: none"> ■ Packing can be used in virtually any kind of fluid ■ Offers flexibility in design
Special end rings	<ul style="list-style-type: none"> ■ Prevent packing extrusion at elevated pressures
Split sets	<ul style="list-style-type: none"> ■ Quick installation ■ Can be cut from solid rings or coil stock

Benefits

- Elimination of costly seal failure or blowouts
- Reduced installation costs
- Reduced equipment downtime with exact seal specifications
- Extended packing and seal life reduces maintenance and operating costs
- Reduced inventory costs

Applications

Since CHEVRON® products have been the industry standard for many years, they can be found as the sealing device in many different types of equipment. Although normally associated with reciprocating applications, CHEVRON® has been used successfully on slow rotating equipment as well.

The most common applications are:

Hydraulic Cylinders	Pneumatic Cylinders	Accumulators	Intensifiers
Jacks	Lifts	Steam Hammers	Valve Stem Packing
Homogenizers	Water Flood Pumps	Fluid Transfer Pumps	Rubber Molding Presses
Bailing Presses	Injection Molding Presses	Extrusion Presses	Forging Presses

Product Selection

The first step in recommending CHEVRON® products is to determine as much as possible about the operating of the equipment, the stuffing box dimensions, environmental conditions, what product(s) have been used before and any related problems.

The data sheet below is provided to help simplify this process:

Equipment Type:

Cylinder _____ Press _____ Pump* _____

Other (explain) _____

Manufacturer _____ Model No. _____

Stuffing Box Data

Shaft, Rod, Ram or Plunger Dia. _____

Stuffing Box Bore _____

Depth of Box _____

Gland, Adjustable Nonadjustable

Maximum Gland Entry _____

Operating Conditions

Fluid Type _____

Manufacturers No. _____

Pressure: _____ Min. _____ Max.

Temperature: _____ Min. _____ Max.

Motion: Reciprocating _____

Length of Stroke _____

Cycles/min. _____

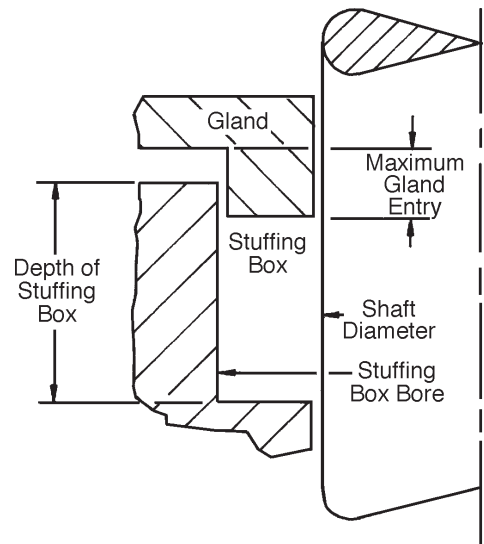

To aid in selecting the proper CHEVRON® packing, please refer to the following pages where information on product compatibility, stack height, pressure ranges and clearances is available.

If factory assistance is required, copy the data sheet section above, fill in the blanks and fax or mail it directly to Garlock Hydraulic Components, fax 315-597-3290.

For other than reciprocating equipment (i.e. rotary, oscillating), contact Garlock for recommendations.

*See page 8 for more detailed information on reciprocating equipment.

Recommended Styles for General Service

Fabric Reinforced Materials										
Style/ Materials of Construction		260RH/ 261RH Cotton Fabric Natural Rubber Rockhard	432/435 Cotton Fabric Nitrile Elastomer	433 Cotton Fabric Butyl Elastomer	532 PolyCotton Fabric Nitrile Elastomer	7960 PolyCotton Fabric Fluoro- elastomer	7532 High Temperature Fabric Nitrile Elastomer	7857RH Cotton Fabric SBR Elastomer Rockhard	7910 PTFE with Hi-Temp Aramid / Fiber Fabric	
Available Forms	Vee-Rings		•	•	•	•	•	•	•	
	Adapters	•	• (432)	•	•	•	•	•		
Recom- mended for Use Against	Air	•	•		•			•	•	
	Acids	•				•			•	
	Aliphatic Solutions	•	•		•	•	•		•	
	Alkalies	•		•		•		•	•	
	Aromatic Solutions					•			•	
	Hydrocarbons	•	•		•	•	•	•	•	
	Ketones								•	
	Phosphate Esters	•		•		•		•	•	
	Steam					• Up to 300°F		• Up to 350°F		•
	Water Glycol	•	•	•	•	•	•	•	•	
	Water in Oil	•	•		•	•	•	•	•	
Temperature	Minimum	-40°F (-40°C)	-40°F (-40°C)	-40°F (-40°C)	-40°F (-40°C)	-20°F (-29°C)	-30°F (-34°C)	-40°F (-40°C)	Cryogenic	
	Maximum	+275°F (+135°C)	+250°F (+121°C)	+250°F (+121°C)	+300°F (+149°C)	+300°F (+149°C)	+325°F (+162°C)	+250°F (+121°C)	+450°F (+232°C)	
Heat Resistance		Good	Good	Good	Very Good	Very Good	Very Good	Good	Very Good	
Pressure Rating ¹		Medium to High	Low to High	Low to High	Low to High	Low to High	Low to High	Medium to High	Medium to High	
Abrasion Resistance		Excellent	Good	Fair	Good	Good	Good	Very Good	Good	
Relative Hardness/ Flexibility		Very Hard/ Rigid	Firm but Flexible	Firm but Flexible	Firm but Flexible	Firm/ Very Flexible	Firm but Rigid	Very Hard/ Rigid	Hard	
Generally Recommended For		Worn or misaligned equipment where extru- sion resistant adapters are needed.	General hydraulic oils, water emulsions. Multi- purpose.	Straight phosphate- ester fluids having no oil or hydro- carbon additives	Moderate to high temperature, oil or steam.	Chemical service, most fire-resistant fluids.	High temperature, oil or steam.	Excellent for water and high pressure service.	All except very low pH fluids. A problem solver.	

1. Pressure ratings are affected by actual condition of equipment, clearances and tolerances, leakage acceptability and other factors. Complete application data could result in slightly different recommendations. Contact the factory with specific questions and/or problems. Other styles available.

Homogeneous Materials

	8452 Homogeneous Nitrile Elastomer	8455 Homogeneous Silicone Elastomer	9188 Homogeneous Butyl Elastomer	9511 Homogeneous Nitrile Elastomer	9600 Homogeneous Fluoro-elastomer	7500 PTFE	7600 PTFE and Graphite	9003 / 9005 Glass Filled Nylon MARBLOCK®
	•	•	•	•	•	•	•	
						•	•	•
	•	•	•	•	•	•	•	•
		•	•		•	•	•	
	•			•	•	•	•	•
		•	•		•	•	•	
					•	•	•	
	•	•		•	•	•	•	•
						•	•	
		•	•		•	•	•	•
						•	•	
	•	•	•	•	•	•	•	•
	•	•		•	•	•	•	•
	0°F (-17°C)	-70°F (-57°C)	-40°F (-40°C)	-20°F (-29°C)	-20°F (-29°C)	Cryogenic	Cryogenic	-65°F (-54°C)
	+225°F (+107°C)	+500°F (+260°C)	+250°F (+121°C)	+250°F (+121°C)	+400°F (+204°C)	+500°F (+260°C)	+500°F (+260°C)	+300°F (+149°C)
	Good	Excellent	Good	Good	Very Good	Excellent	Excellent	Good
	Vacuum to Low	Vacuum to Low	Vacuum to Low	Vacuum to Low	Vacuum to Low	Low to Medium	Low to Medium	High
	Good	Fair	Good	Good	Good	Very Good	Very Good	Excellent
	90 Duro Flexible	80 Duro Flexible	90 Duro Flexible	70 Duro Flexible	80 Duro Flexible	Firm/ Rigid	Hard/ Rigid	Very Hard/ Rigid
	MIL-R-3065, General purpose oil, air and water service.	Most fluids except strong acids and alkalis or steam.	Same as style 433. For low pressure service.	General purpose—air, oil and water service.	Low pressure seals in high temperature, and chemical service.	Excellent for all fluids, non-lubricated service or food processing.	Especially suitable for soot blowers.	Excellent bearing material for hydraulic cylinders. Low break-away friction. High strength.

WARNING:

Properties/applications shown throughout this brochure are typical. Your specific application should not be undertaken without independent study and evaluation for suitability. For specific application recommendations consult Garlock. Failure to select the proper sealing products could result in property damage and/or serious personal injury.

Performance data published in this brochure has been developed from field testing, customer field reports and/or in-house testing. While the utmost care has been used in compiling this brochure, we assume no responsibility for errors. Specifications subject to change without notice. This edition cancels all previous issues. Subject to change without notice.

CHEVRON® Stack Height Table

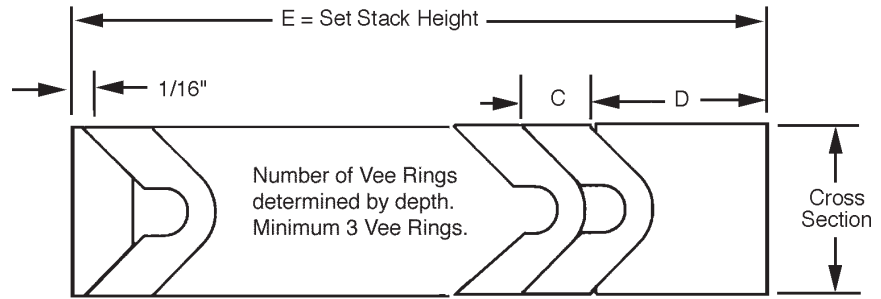

Cross-section	STACK HEIGHT		TOTAL DEPTH "E" (includes the adapter set plus the number of CHEVRON x "C")									
	CHEVRON "C"	Adapter Set "D" + 1/16"	1	2	3	4	5	6	7	8	9	10
	3/16" 0.188"	7/64" 0.109"	5/16" 0.313"	27/64" 0.422"	17/32" 0.531"	41/64" 0.641"	3/4" 0.750"	55/64" 0.859"	31/32" 0.969"	1-5/64" 1.078"	1-3/16" 1.188"	1-19/64" 1.297"
7/32" 0.219"	7/64" 0.109"	5/16" 0.313"	27/64" 0.422"	17/32" 0.531"	41/64" 0.641"	3/4" 0.750"	55/64" 0.859"	31/32" 0.969"	1-5/64" 1.078"	1-3/16" 1.188"	1-19/64" 1.297"	1-13/32" 1.406"
1/4" 0.250"	7/64" 0.109"	5/16" 0.313"	27/64" 0.422"	17/32" 0.531"	41/64" 0.641"	3/4" 0.750"	55/64" 0.859"	31/32" 0.969"	1-5/64" 1.078"	1-3/16" 1.188"	1-19/64" 1.297"	1-13/32" 1.406"
9/32" 0.281"	5/32" 0.156"	11/32" 0.344"	1/2" 0.500"	21/32" 0.656"	13/16" 0.813"	31/32" 0.969"	1-1/8" 1.125"	1-9/32" 1.281"	1-7/16" 1.438"	1-19/32" 1.594"	1-3/4" 1.750"	1-29/32" 1.906"
5/16" 0.313"	11/64" 0.172"	3/8" 0.375"	35/64" 0.547"	23/32" 0.719"	57/64" 0.891"	1-1/16" 1.063"	1-15/64" 1.234"	1-13/32" 1.406"	1-37/64" 1.578"	1-3/4" 1.750"	1-59/64" 1.922"	2-3/32" 2.094"
11/32" 0.344"	3/16" 0.188"	13/32" 0.406"	19/32" 0.594"	25/32" 0.781"	31/32" 0.969"	1-5/32" 1.156"	1-11/32" 1.344"	1-17/32" 1.531"	1-23/32" 1.719"	1-29/32" 1.906"	2-3/32" 2.094"	2-9/32" 2.281"
3/8" 0.375"	3/16" 0.188"	7/16" 0.438"	5/8" 0.625"	13/16" 0.813"	1" 1.000"	1-3/16" 1.188"	1-3/8" 1.375"	1-9/16" 1.563"	1-3/4" 1.750"	1-15/16" 1.938"	2-1/8" 2.125"	2-5/16" 2.313"
13/32" 0.406"	3/16" 0.188"	15/32" 0.469"	21/32" 0.656"	27/32" 0.844"	1-1/32" 1.031"	1-7/32" 1.219"	1-13/32" 1.406"	1-19/32" 1.594"	1-25/32" 1.781"	1-31/32" 1.969"	2-5/32" 2.156"	2-11/32" 2.344"
7/16" 0.438"	15/64" 0.234"	1/2" 0.500"	47/64" 0.734"	31/32" 0.969"	1-13/64" 1.203"	1-7/16" 1.438"	1-43/64" 1.472"	1-29/32" 1.906"	2-9/64" 2.141"	2-3/8" 2.375"	2-39/64" 2.609"	2-27/32" 2.844"
15/32" 0.469"	15/64" 0.234"	9/16" 0.563"	51/64" 0.797"	1-1/32" 1.031"	1-17/64" 1.266"	1-1/2" 1.500"	1-47/64" 1.734"	1-31/32" 1.969"	2-13/64" 2.203"	2-7/16" 2.438"	2-43/64" 2.672"	2-29/32" 2.906"
1/2" 0.500"	15/64" 0.234"	19/32" 0.594"	53/64" 0.828"	1-1/16" 1.063"	1-19/64" 1.297"	1-17/32" 1.531"	1-49/64" 0.766"	2" 2.000"	2-15/64" 2.234"	2-15/32" 2.469"	2-45/64" 2.703"	2-15/16" 2.938"
17/32" 0.219"	15/64" 0.234"	5/8" 0.625"	55/64" 0.859"	1-3/32" 1.094"	1-21/64" 1.328"	1-9/16" 1.563"	1-51/64" 1.797"	2-1/32" 2.031"	2-17/64" 2.266"	2-1/2" 2.500"	2-47/64" 2.734"	2-31/32" 2.969"
9/16" 0.563"	15/64" 0.234"	21/32" 0.656"	57/64" 0.891"	1-1/8" 1.125"	1-23/64" 1.359"	1-19/32" 1.594"	1-53/64" 1.828"	2-1/16" 2.063"	2-19/64" 2.297"	2-17/32" 2.531"	2-49/64" 2.766"	3" 3.000"
5/8" 0.625"	9/32" 0.281"	23/32" 0.719"	1" 1.000"	1-9/32" 1.281"	1-9/16" 1.563"	1-27/32" 1.844"	2-1/8" 2.125"	2-13/32" 2.406"	2-11/16" 2.688"	2-31/32" 2.969"	3-1/4" 3.250"	3-17/32" 3.531"
11/16" 0.688"	9/32" 0.281"	25/32" 0.781"	1-1/16" 1.063"	1-11/32" 1.344"	1-5/8" 1.625"	1-29/32" 1.906"	2-3/16" 2.188"	2-15/32" 2.469"	2-3/4" 2.750"	3-1/32" 3.031"	3-5/16" 3.313"	3-19/32" 3.594"
3/4" 0.750"	21/64" 0.328"	27/32" 0.844"	1-11/64" 1.172"	1-1/2" 1.500"	1-53/64" 1.828"	2-5/32" 2.156"	2-31/64" 2.484"	2-13/16" 2.813"	3-9/64" 3.141"	3-15/32" 3.469"	3-51/64" 3.797"	4-1/8" 4.125"
13/16" 0.813"	21/64" 0.328"	29/32" 0.844"	1-15/64" 1.234"	1-9/16" 1.563"	1-57/64" 1.891"	2-7/32" 2.219"	2-35/64" 2.547"	2-7/8" 2.875"	3-13/64" 3.203"	3-17/32" 3.531"	3-55/64" 3.859"	4-3/16" 4.188"
7/8" 0.875"	3/8" 0.375"	1" 1.000"	1-3/8" 1.375"	1-3/4" 1.750"	2-1/8" 2.125"	2-1/2" 2.500"	2-7/8" 2.875"	3-1/4" 3.250"	3-5/8" 3.625"	4" 4.000"	4-3/8" 4.375"	4-3/4" 4.750"
15/16" 0.938"	3/8" 0.375"	1-1/16" 1.063"	1-7/16" 1.438"	1-13/16" 1.813"	2-3/16" 2.188"	2-9/16" 2.563"	2-15/16" 2.938"	3-5/16" 3.313"	3-11/16" 3.688"	4-1/16" 4.063"	4-7/16" 4.438"	4-13/16" 4.813"
1" 1.000"	13/32" 0.406"	1-1/8" 1.125"	1-17/32" 1.531"	1-15/16" 1.938"	2-11/32" 2.344"	2-3/4" 2.750"	3-5/32" 3.156"	3-9/16" 3.563"	3-31/32" 3.969"	4-3/8" 4.375"	4-25/32" 4.781"	5-3/16" 5.188"
1-1/16" 1.063"	13/32" 0.406"	1-3/16" 1.188"	1-19/32" 1.594"	2" 2.000"	2-13/32" 2.406"	2-13/16" 2.813"	3-7/32" 3.219"	3-5/8" 3.625"	4-1/32" 4.031"	4-7/16" 4.438"	4-27/32" 4.844"	5-1/4" 5.250"
1-1/8" 1.125"	29/64" 0.453"	1-1/4" 1.250"	1-45/64" 1.703"	2-5/32" 2.156"	2-39/64" 2.609"	3-1/16" 3.063"	3-33/64" 3.516"	3-31/32" 3.969"	4-27/64" 4.578"	4-7/8" 4.875"	5-21/64" 5.328"	5-25/32" 5.781"
1-3/16" 1.188"	1/2" 0.500"	1-5/16" 1.313"	1-13/16" 1.813"	2-5/16" 2.313"	2-13/16" 2.813"	3-5/16" 3.313"	3-13/16" 3.813"	4-5/16" 4.313"	4-13/16" 4.813"	5-5/16" 5.313"	5-13/16" 5.813"	6-5/16" 6.313"
1-1/4" 1.250"	1/2" 0.500"	1-3/8" 1.375"	1-7/8" 1.875"	2-3/8" 2.375"	2-7/8" 2.875"	3-3/8" 3.375"	3-7/8" 3.875"	4-3/8" 4.375"	4-7/8" 4.875"	5-3/8" 5.375"	5-7/8" 5.875"	6-3/8" 6.375"

NOTES

- Heights are approximate. Exact height cannot be guaranteed.
- Table applies to fabric-reinforced CHEVRON® sets only.
- Due to space restrictions we cannot list all of our size capabilities such as large cross sections, metric sizes, optional stack heights, and a multitude of size variations cut from coil.

Vee Ring and Adapter Designs

A. Fabric - Hinge - Type XE

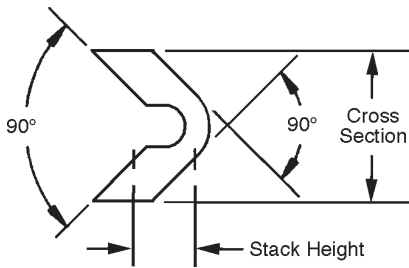

E. PTFE Male Adapter

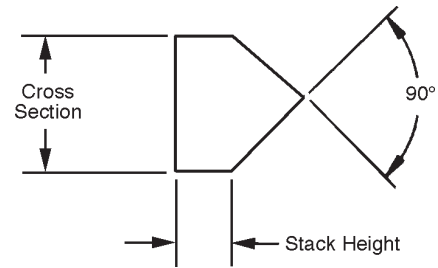

B. Fabric - Modified Hinge - Type GX

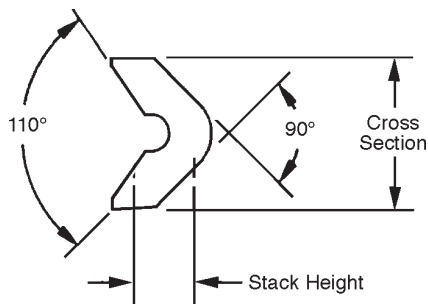

F. PTFE Vee Ring

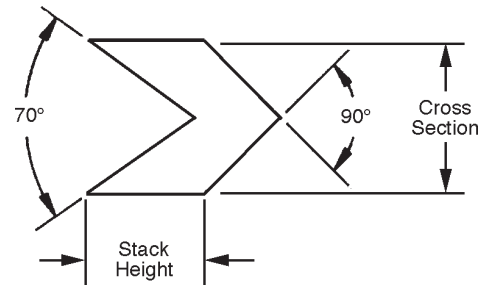

C. Homogeneous Rubber - No Hinge - Type NH

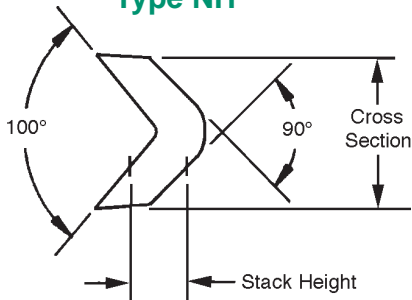

G. PTFE Female Adapter

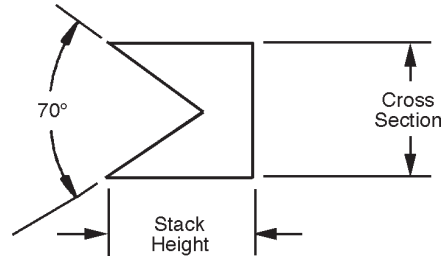

D. Fabric and Metal Adapters

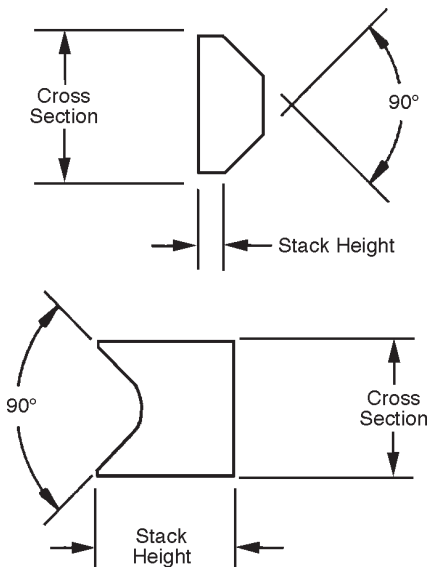

PTFE Stack Heights (inches)

Cross Section	Male (E) Std./J.I.C.	Vee Ring (F) Std./J.I.C.	Female (G) Std. or J.I.C.
0.188	0.075/0.063	0.150/0.083	0.188
0.219	0.088/0.063	0.175/0.083	0.219
0.250	0.100/0.063	0.200/0.083	0.250
0.313	0.125/0.063	0.250/0.140	0.313
0.375	0.150/0.063	0.300/0.156	0.375
0.438	0.175/0.063	0.350/0.197	0.438
0.500	0.200/0.063	0.400/0.197	0.500
0.563	0.225/0.063	0.450/0.197	0.563
0.625	0.250/0.063	0.500/0.250	0.625
0.750	0.300/0.063	0.600/0.297	0.750

WARNING:

Properties/applications shown throughout this brochure are typical. Your specific application should not be undertaken without independent study and evaluation for suitability. For specific application recommendations consult Garlock. Failure to select the proper sealing products could result in property damage and/or serious personal injury.

Performance data published in this brochure has been developed from field testing, customer field reports and/or in-house testing. While the utmost care has been used in compiling this brochure, we assume no responsibility for errors.

Specifications subject to change without notice. This edition cancels all previous issues. Subject to change without notice.

Design Parameters

Number of Vee Rings by Application

Piston Applications

Diameter of Cylinder	Zero to 1000 psi		1000-2500 psi		2500-4000 psi		4000 psi and Up	
	Cross Section	Vee Rings per Set	Cross Section	Vee Rings per Set	Cross Section	Vee Rings per Set	Cross Section	Vee Rings per Set
1" to 2"	1/4"	3	1/4"	4	5/16"	4	3/8"	5
2" to 3"	5/16"	3	5/16"	4	5/16"	4	3/8"	5
3" to 6"	3/8"	3	3/8"	4	3/8"	4	3/8"	5
6" to 8"	1/2"	3	1/2"	4	1/2"	4	1/2"	5
8" to 14"	5/8"	3	5/8"	4	5/8"	4	5/8"	5

Rod, Plunger or Ram Applications

Diameter of Rod Plunger or Ram	Zero to 1000 psi		1000-2500 psi		2500-4000 psi		4000 psi and Up	
	Cross Section	Vee Rings per Set	Cross Section	Vee Rings per Set	Cross Section	Vee Rings per Set	Cross Section	Vee Rings per Set
1" to 3"	1/4"	4	1/4"	5	5/16"	5	5/16"	6
3" to 6"	1/4"	4	5/16"	5	3/8"	5	3/8"	6
6" to 8"	5/16"	4	3/8"	5	1/2"	5	1/2"	6
8" to 14"	3/8"	4	1/2"	5	1/2"	5	5/8"	6
14" to 24"	1/2"	4	5/8"	5	5/8"	5	3/4"	6
24" to 36"	5/8"	4	3/4"	5	3/4"	5	1"	6
36" and Up	3/4"	4	1"	5	1"	5	1"	6

Recommended Adapters for Pressure Ranges

Adapter Type	1000 psi	2000 psi	3000 psi	5000 psi
Standard Fabric	■	■		
Rockhard Fabric		■	■	
Bronze			■	■
MARBLOCK®	■	■	■	

NOTE:

See Stack Height Table on page 4 for the height of the Vee rings plus male and female adapter rings per set. This table is for general guidance. Many satisfactory Garlock CHEVRON® packing installations can be made with variations in the recommended equipment or packing guidelines.

Clearances

If excessive clearance exists between the cylinder wall or the shaft and the component supporting the female adapter, operating pressure will extrude the adapter into the clearance. The greater the pressure and clearance, the more quickly extrusion will occur. In a clean system, where concentricity requirements are met, and where minimum clearances are held, optimum seal life can be expected.

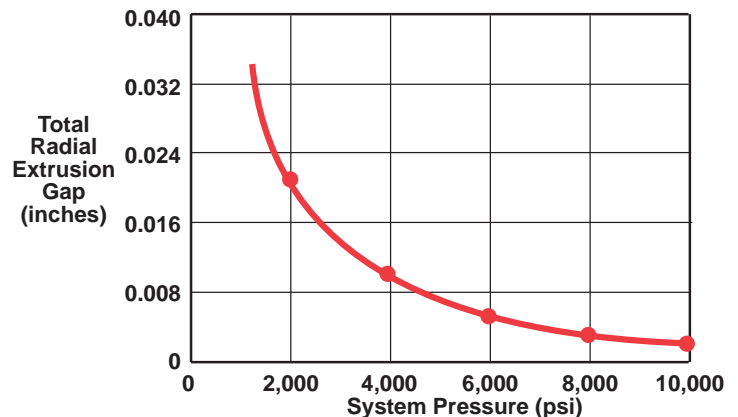

Deep V-Ring CHEVRON® Packing

For large diameter, deep stuffing box applications

- Easier installation—fewer rings required
- Quicker turnaround—rings won't "roll-over" during installation
- Wide variety of styles—choose from the many popular fabric and rubber styles available from Garlock to suit your application
- Few size restrictions—made in our continuous process, so large diameters are no problem
- Most popular cross sections are: 5/8", 3/4", 7/8", 1"

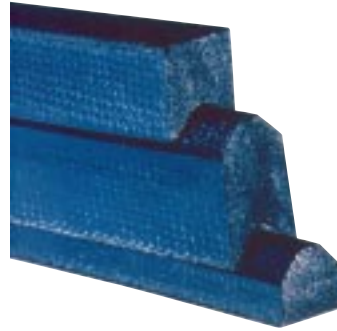

CHEVRON® Packings for High Pressure Service

In unusually high pressure applications, CHEVRON® packing might need to be reinforced to prevent undue distortion from this extreme pressure. The following are examples of some design considerations that can be used to overcome problems experienced with standard components (such as 432, 433, etc.).

"D" filler rings can be installed in the groove of the hinge-type CHEVRON® Vee Rings to prevent distortion of the packing without interfering with the automatic hinge action of the rings. If the CHEVRON® Vee Rings still tend to telescope into each other, metal separators (lead or bronze) can be installed between the CHEVRON® Vee Rings.

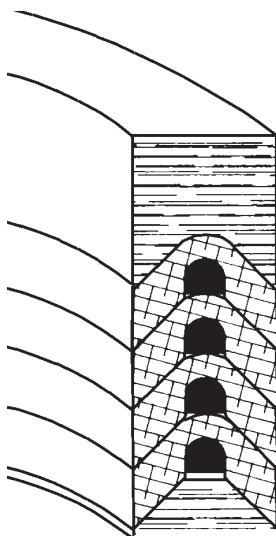

CHEVRON® packing with "D" shaped filler rings.

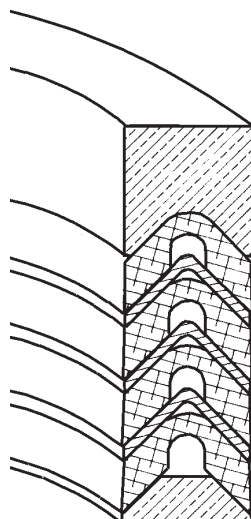

CHEVRON® packing with metal separators and adapters

"D" fillers can be used only with 3/8" cross sections and up with hinge type "XE" CHEVRON® rings per illustration A, page 5.

When pressure ranges exceed those normally satisfied with standard Style 432, 433 or 532 adapters, the stronger rockhard adapters such as 260RH, 261RH and 7857RH should be considered.

When a problem relates to excessive clearances, as discussed on page 6, a close tolerance phenolic (Style 155) or bronze bushing installed behind the female adapter will act as additional support and reduce the extrusion gap. A phenolic or bronze female adapter will serve the same purpose.

These configurations have been used successfully to extend the life of CHEVRON® packing sets. However, specific applications should be considered on an individual basis, taking into account the type of equipment, size, temperature, media being sealed, pressure, surface speed, condition of equipment and any other contributing factors.

WARNING:

Properties/applications shown throughout this brochure are typical. Your specific application should not be undertaken without independent study and evaluation for suitability. For specific application recommendations consult Garlock. Failure to select the proper sealing products could result in property damage and/or serious personal injury.

Performance data published in this brochure has been developed from field testing, customer field reports and/or in-house testing. While the utmost care has been used in compiling this brochure, we assume no responsibility for errors.

Specifications subject to change without notice. This edition cancels all previous issues. Subject to change without notice.

Seals for Reciprocating Plunger Pump Applications

Garlock has long been a leader in the development of seals and packings for reciprocating equipment. The CHEVRON® trade name for vee packing was registered over 70 years ago; and although it is very popular for use in such applications as hydraulic cylinders and hydraulic presses, it also is capable of providing excellent performance for the demanding service conditions found in plunger pumps.

As noted on the adjacent page, our Style 8380 LOCK-PACK™ can be used in the most common reciprocating pump applications where a nonadjustable packing is desired.

However, when unusual operating conditions, size or the need for an adjustable packing set rules out the use of LOCK-PACK™, it is important to be able to offer alternative packing recommendations. With hundreds of tooled sizes available in numerous materials, Garlock CHEVRON® provides the options necessary to meet the changing needs of Simplex and Multiplex pumps.

Over the years Garlock has developed styles specifically for plunger pump applications. Although other materials are available, one of the following packing styles will most likely provide satisfactory service:

- 8024: SBR rubber/cotton fabric, rockhard cure
- 8064: SBR rubber/cotton fabric, standard cure
- 8140: SBR rubber/polyester-cotton fabric, rockhard cure
- 8150: NBR/PTFE/polyester-cotton fabric, standard cure

In addition to selecting the proper material for an application, the packing arrangement and design of the other packing set components are equally important. Bronze is the material of choice for male and female adapters or lantern rings to provide plunger alignment through the sealing CHEVRON®, as well as prevent its extrusion. Figures 1 through 4 illustrate some common packing assemblies.

Since stuffing box spaces vary with pump models, it may be necessary to have Garlock design the packing set. The minimum information necessary to do so should include the operating conditions and details of the packing area, which may be best covered by a drawing.

Garlock has the products, experience and quality to satisfy your plunger pump packing needs.

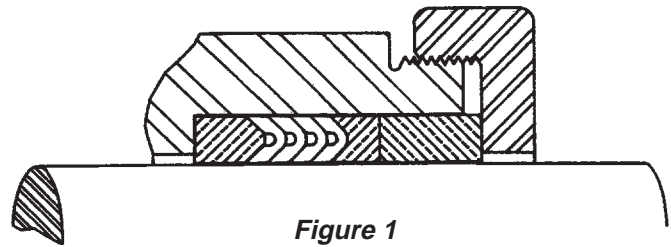

Figure 1
Non-lubricated box
Adjustable CHEVRON® set

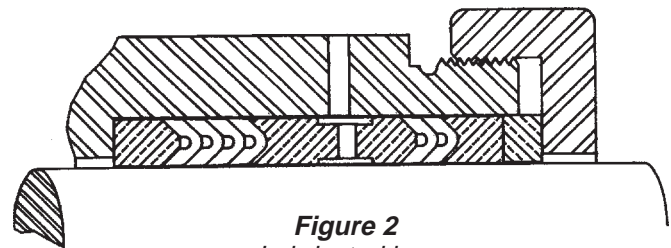

Figure 2
Lubricated box
Adjustable primary and
secondary CHEVRON® sets

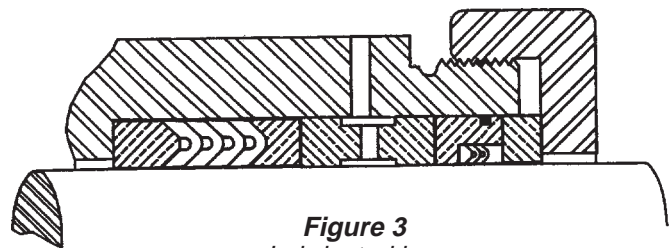

Figure 3
Lubricated box
Adjustable primary CHEVRON® set
Non-adjustable secondary CHEVRON® set

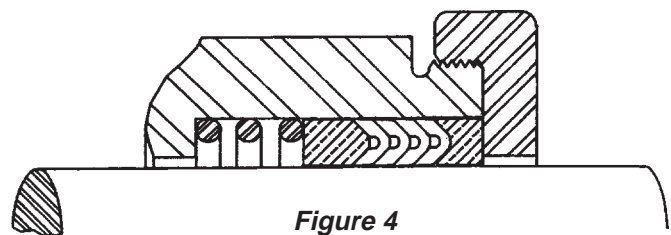

Figure 4
Non-lubricated box
Spring-loaded self-adjusting
CHEVRON® set

WARNING:

Properties/applications shown throughout this brochure are typical. Your specific application should not be undertaken without independent study and evaluation for suitability. For specific application recommendations consult Garlock. Failure to select the proper sealing products could result in property damage and/or serious personal injury.

Performance data published in this brochure has been developed from field testing, customer field reports and/or in-house testing. While the utmost care has been used in compiling this brochure, we assume no responsibility for errors.

Specifications subject to change without notice. This edition cancels all previous issues. Subject to change without notice.

CHEVRON® Installation and Adjustment

Protect your investment. Do not hang Garlock CHEVRON® packing on nails or under any excessive stack pressure that might deform the concentricity of the product. Do not stock in extreme weather conditions. Avoid constant sunlight. The elastomer compounds used in CHEVRON® packing are highly technical and, while reliable, they are subject to handling stress.

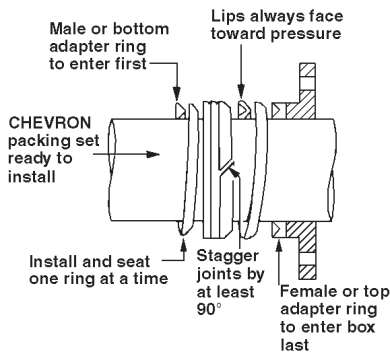

1. Packing on a moving ram should be endless rings, if possible, for best service life.
2. If rams are grooved, worn, rusted or corroded, they should be re-conditioned or replaced. No packing stands up to these conditions. Use boots to protect rams if abrasive dust is a problem.
3. On high pressure jobs, make clearance between rod and gland as close as possible to prevent extrusion.
4. If lubrication is not getting into a Garlock CHEVRON® packing set, the gland may be drawn up too tightly and should be loosened appropriately. To avoid over-tightening and/or cocking of the gland, place a shim under the gland.

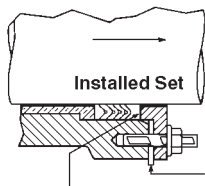

Adjustable gland should fit snugly against packing—Use shims as necessary to prevent crushing the rings

5. If a stuffing box is very deep, spacer(s) can be used to take up the space of additional CHEVRON® rings that are not needed.

This saves replacement time and cost.

6. Use the correct style. For example, don't use butyl against a petroleum base oil, or a nitrile against a phosphate ester.
7. Use the right size. In emergencies, "off-size" parts can be distorted and made to work for a short period of time, but do not expect them to last or do as efficient a job as the correct size.
8. Make sure all rings are seated with no voids in the set.
9. Use lubrication when installing the rings, as it makes installation much easier and helps during the break-in period.
10. Make sure sections of the lips of the rings are not turned over or twisted. This is easy to do, especially in blind installation, and will result in premature leakage and failure.
11. Make sure the packings are facing in the direction of the medium being sealed—whether liquid, air, dust, etc.
12. Consider metal structure. Many times a packing is blamed for leakage when the real culprit is porous metal—either the rod or the housing.
13. Let Garlock help you. Tell us about the application. If a forging press is under shock load, then packing must be a more rugged type, for example. Or, if low pressures are involved, the packing selection must be more flexible than for high pressure.
14. Don't use sharp metal tools like screwdrivers when installing packings. Hardwood tools are best and will not score rod or stuffing box.

For installation of endless CHEVRON® packing, gland pressure should be only sufficient to snug rings within the confining cavity.

On split ring installations, adjustment practice will vary depending on service conditions.

For horizontal packing installations, nominally light gland pressure is necessary to seal the ring joints. Adjustment is made by turns of 1/4 flat on gland bolts.

On vertical applications of split rings it is desirable to provide increased gland pressure for the effective seal of ring joints.

Style 8380 LOCK-PACK™



Non-adjustable plunger pump packing

These non-adjustable pump packing sets consist of male adapters, pressure rings and female adapters. Sets are designed using several of these components in various combinations as required for the specific pump model. The most popular sets consist of 2, 3 or 4 units, each containing a male adapter, pressure ring and female adapter. The pressure rings are molded in an endless form, eliminating weaknesses found in parts molded with vulcanized joints. Added strength comes from a solid phenolic-based core that is fully encapsulated with a polyester and cotton fabric reinforced nitrile elastomer.

The adapters are made of MARBLOCK®, Garlock's high-strength glass-reinforced plastic material. This tough and rigid material provides the "bearing" and anti-extrusion qualities necessary for a high-performance female adapter.

Style 8380 will stand up against fresh and salt water, propane, butane, gasoline, oil and miscellaneous mild chemicals and acids.

Features

Unitized construction

Crush-proof core

Endless blank construction

Advantages

■ Each pressure ring receives individual support

■ Resists over tightening of glands

■ No vulcanized joints to weaken

Benefits

- Increased packing life reduces replacement (maintenance) costs
- Less equipment downtime decreases operating costs
- Elimination of time-consuming adjustments
- Eliminates costs associated with premature set failure

Specifications

Temperature: -40°F (-40°C) to +275°F (+135°C)

Pressure: Up to 3,500 psi (240 bar)

9220 GARTHANE® U-Seals

Strength/Durability

- Four times the tensile strength / tear resistance of conventional seals
- High modulus counteracts extrusion and shear forces
- Withstands shocks over a wide range of temperatures and pressures
- Exceptional abrasion resistance
- Outstanding endurance under difficult operating conditions

Flexibility

- Excellent elasticity
- Excellent resilience
- Withstands high degree of deformation

Temperature and Chemical Resistance

- Excellent for use against petroleum based fluids to 225°F (107°C); air, warm water and water glycol to 180°F (82°C)
- Withstands dilute acetic and alkaline solutions, aliphatic alcohols and hydrocarbons, salts and solutions of aromatics and solids in concentrations under 80%
- Not recommended for use with very strong oxidizers, highly concentrated acids or bases, pure aromatic compounds, esters, ketones, automotive brake fluid or steam

Pressure Resistance

- Compounded to withstand a wide range of pressure conditions
 - Normally used as hydraulic cylinder or large ram press seals to 3,500 psi (242 bar)
 - Successfully used for slow-moving equipment to 8,000 psi (552 bar), and static applications to 30,000 psi (2,070 bar) on specially adapted equipment



Features

90 Durometer Urethane

Reverse bevel lip design

Balanced design

Clear Urethane

Extensive tooling list

Advantages

■ High tensile strength

■ High tear resistance

■ Less friction

■ Responds immediately to pressure

■ Can function as a rod or piston seal

■ No hidden defects in seal

■ Greater size availability — both inch and metric

Benefits

- Increased seal life and performances
- Less equipment downtime
- Fewer sizes save inventory expense
- Eliminates chance of costly premature equipment failure

Recommended Tolerances and Finishes

- Shaft hardness: 30 Rockwell C (minimum)
- Groove length (axial): Height of U-seal plus 10% of cross section (0.032 minimum)
- Dynamic surface finish: 10 to 20 RMS
Tolerance: ± 0.003 (maximum)
- Static surface finish: 60 RMS (maximum)
Tolerance: ± 0.005 (maximum)

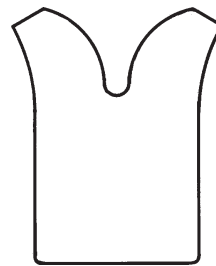

Standard Design
Cross Section

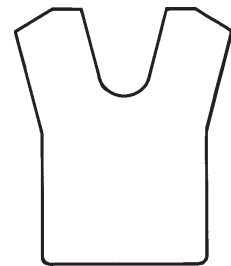

Metric Design
Cross Section

WARNING:

Properties/applications shown throughout this brochure are typical. Your specific application should not be undertaken without independent study and evaluation for suitability. For specific application recommendations consult Garlock. Failure to select the proper sealing products could result in property damage and/or serious personal injury.

Performance data published in this brochure has been developed from field testing, customer field reports and/or in-house testing. While the utmost care has been used in compiling this brochure, we assume no responsibility for errors.

Specifications subject to change without notice. This edition cancels all previous issues. Subject to change without notice.

Polytop Sets

These unique set configurations have found widespread popularity due to their high sealing efficiency.

A Garlock Polytop CHEVRON® set utilizes both squeeze and multiple lip type seals. Used in a set configuration, these two proven designs combine to provide maximum sealing performance.

Squeeze seals, such as the Garlock 9220 polyurethane U-Seal, provide excellent low pressure sealing performance.

Lip seals, such as Garlock 432 CHEVRON®, provide low friction rates while maintaining responsiveness to pressure fluctuations.

Compounded from the highest quality urethane, the Garlock 9220 U-Seal is strong and abrasion-resistant. In the Polytop configuration, it replaces the traditional top adapter used with vee sets and provides an additional sealing lip.

The fabric and rubber composition of Garlock 432 CHEVRON® provides a strong, yet flexible sealing system that dampens any pressure surges.

Unlike typical vee sets, Garlock Polytop sets need no axial preload or adjustment after startup, virtually eliminating the fear of catastrophic failure.

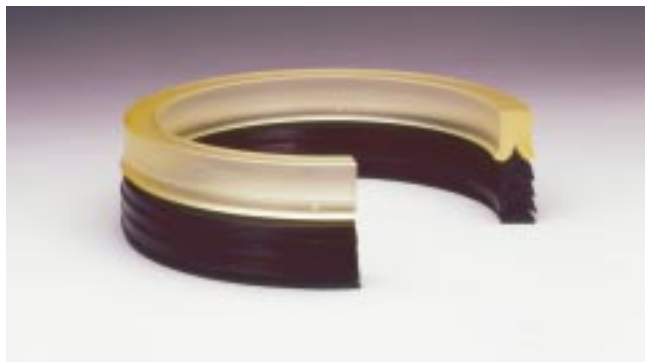

SLUDGE-PAK® Packing



For vertical sludge pumps

These unique, combination sets from Garlock for use in Carter, Marlow, Koline Sanderson and Passavant vertical sludge pumps have gained wide acceptance in the waste treatment industry.

SLUDGE-PAK™ hydraulic packing sets are designed to reduce the friction and abrasion so often associated with vertical sludge pumps. This unique packing arrangement decreases the chance of scoring plungers as might occur with the use of a packing set consisting only of braided packing.

The set's function is based upon the qualities of three types of packing. In the bottom of the stuffing box is Style 8921-K. Next is Style 432 CHEVRON® sealing rings. Topping off the set is a Style 9220 GARTHANE® (urethane) U-seal.

Garlock SLUDGE-PAK™ packing is the best of three worlds... braided packing, CHEVRON® rings and urethane U-seals. The performance is unbeatable and necessary in today's waste treatment industry.

Polytop sets and SLUDGE-PAK™ packing

Polytop sets and SLUDGE-PAK™ are similar in design because they combine different styles of packing. In performance, where it counts, these unique sets offer some significant features and benefits.

Features

The best properties of each component improve sealability

Combined styles react better to varying pressure conditions

Individual components do not cause equipment damage

Benefits

■ Longer life, fewer repacks

■ Less chance of costly premature failure

■ Reduces expensive downtime and wear on spare parts

Roll Balance

Unique combination sets for the steel and aluminum industries

Roll Balance is commonly found in mills where molten metal slab is reduced to a gauged strip.

Roll Balance sets consist of a CHEVRON® set or a GARTHANE® U-seal to act as the sealing component, and a special diagonal cut ring to act as a piston bearing and anti-extrusion ring for the CHEVRON® set or U-seal.

As pressure is applied, the 155 diagonal cut ring acts in opposite outward directions for positive support of the piston, while reducing the extrusion gap behind the CHEVRON® set or GARTHANE® U-seal.

Features

Advantages

9220 U-seal	<ul style="list-style-type: none">■ Reverse bevel lip■ Balanced design■ Clear 90 Duro urethane composition
155 diagonal cut ring	<ul style="list-style-type: none">■ Bearing/backup ring■ Prevents extrusion by closing gap

Benefits

- Product loss minimized
- Prolonged packing life reduces overall labor costs
- Less equipment downtime
- Reduced cylinder wear, lower operational costs
- Available in sizes to fit most Mesta, United and Blaw-Knox roll balance cylinders
- Complete set is asbestos-free

Specifications

Pressures: 3,000 psi (205 bar) average operating with surges exceeding the operating pressure

Temperature: 150°F (65°C) to 200°F (95°C)

Medium: Hydraulic oil with the presence of water



Style 9003 MARBLOCK® Wear Rings

Non-scoring and superior wear

MARBLOCK® Wear Rings are used mainly in heavy-duty hydraulic cylinders as a bearing to prevent scoring between piston and cylinder bore. Style 9003 excels in wear and life expectancy, compared with other rings in use today.

Garlock MARBLOCK® Wear Rings are smoother, harder, better bearings. They will pick up and absorb foreign particles in the cylinder and help keep cylinder area clear of metal pieces. Yet, they have no inherent imbedded materials that can score cylinder walls. That adds up to smooth, unhampered piston operation, greater overall efficiency and longer cylinder life.

Specify Garlock MARBLOCK® Wear Rings. They're available in a wide range of sizes for new equipment and will fit most existing grooves in present equipment.

Piston Cups

For hydraulic and pneumatic pistons

- Simple design, single lip automatic seal
- Wide range of standard materials
- Minimum space requirement

Garlock piston cups are engineered to seal static and dynamic loads in most piston applications. Although the specific operating conditions will dictate the material choice, our piston cups are generally recommended for air, water, oils, greases, solvents and gases.

The wide range of available materials allows us the flexibility to recommend the right piston cup for a specific application. For example, our homogeneous cups are used in pneumatic and light hydraulic services. The fabric-inserted cups are the most popular because they work well in normal hydraulic services at pressures up to 3,500 psi (242 bar). In heavy-duty applications, our metal-backed cups provide the long life required for these difficult services.

Garlock has the quality, materials, and experience to satisfy your piston cup application.

WARNING:

Properties/applications shown throughout this brochure are typical. Your specific application should not be undertaken without independent study and evaluation for suitability. For specific application recommendations consult Garlock. Failure to select the proper sealing products could result in property damage and/or serious personal injury.

Performance data published in this brochure has been developed from field testing, customer field reports and/or in-house testing. While the utmost care has been used in compiling this brochure, we assume no responsibility for errors.

Specifications subject to change without notice. This edition cancels all previous issues. Subject to change without notice.

Model 79 Rod Scrapers

Set new standards of efficiency in excluding dirt, mud and metal chips in demanding equipment applications

Durability

- Four times the tensile strength/tear resistance of nitrile materials
- High modulus for optimum scraping action
- Exceptional abrasion resistance
- Outstanding endurance under difficult operating conditions

Flexibility

- Exhibits excellent elasticity
- Exhibits excellent resilience
- Withstands high degree of deformation

Applications

- Hydraulic cylinders
- Track adjusters
- Available as pin seals with a special formulation of polyurethane for oscillating linkage pin assemblies

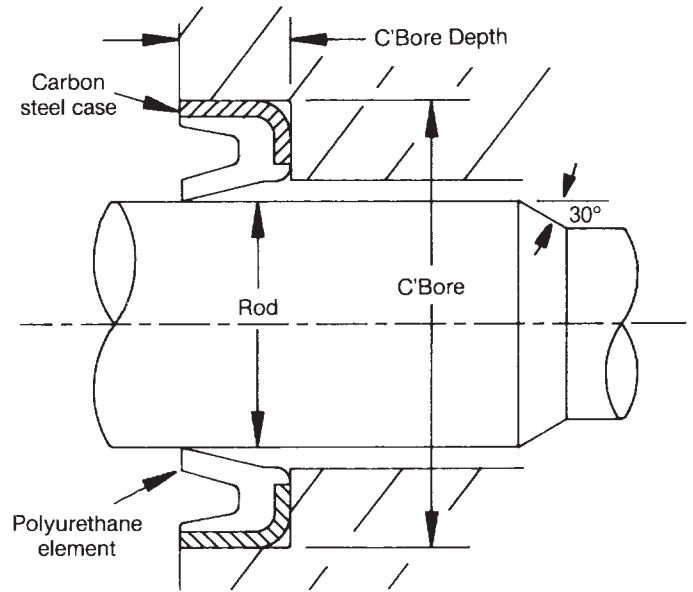

Typical Installation

Features	Advantages
Press fit design	■ Easy retrofit in existing counterbore
Exclusive urethane lip configuration	■ Non-scoring ■ Accepts greater side-loading / rod eccentricity
Superior bond of element to steel case	■ Greater concentricity and rebound characteristics
Extensive line of tooling	■ Available in a wide range of inch and metric sizes

Benefits

- Saves time on installation
- Eliminates costly damage to equipment from contaminants
- Extended life
- Reduced vendor base

Recommended Tolerances and Finishes

- **Rod**
 - Chamfer
 - Up to 2" 30° x 3/32" axially
 - 2" to 6" 30° x 5/32" axially
 - 6" & up 30° x 1/4" axially
 - Hardness 30 Rockwell C (minimum)
 - Tolerance ±0.003"
 - Finish 20 rms (maximum)
 - Speed 50 fpm (typical)
- **Counterbore**
 - Tolerance
 - Up to 3" ±0.001"
 - 3" to 6" ±0.0015"
 - 6" to 10" ±0.002"
 - 10" to 20" +0.002", -0.004"
 - Finish 60 rms (maximum)
 - Depth tolerance
 - Up to 6" diameter +1/64", -0"
 - 6" & up diameter +1/32", -0"
 - Chamfer None required

More than just great products...

Beyond offering you the widest available range of products for packing and sealing, Garlock enhances the value of its products with technical services and comprehensive training programs:

- ISO 9002-94 registration for Industrial Gasketing, Industrial Packing, KLOZURE® Oil Seals, Bearing Protectors, Expansion Joints, Hydraulic Components, Mechanical Seals, and Industrial Rubber Products.
- A global network of stocking Authorized Garlock Distributors.
- Factory sales representatives and applications engineers available for problem solving when and where it is needed.
- Toll-free 800 telephone and FAX numbers for immediate product information.
- In-plant surveys of equipment and processes, providing the customer with recommendations to identify and eliminate sealing and packing problems before they start.
- The most sophisticated and most comprehensive test facilities available.
- Technical field seminars on all Garlock products.
- Factory-sponsored product training programs, including hands-on seminars, to ensure that Garlock representatives and their distributor personnel are the best in the industry.
- Technical Bulletins to keep you up-to-date on product enhancements and changes.

Customers who specify Garlock fluid sealing products get, at no extra cost, the high quality support needed to run a profitable operation.

AUTHORIZED DISTRIBUTOR



ISO 9002-94
Cert. #001762

WARNING:

Properties/applications shown throughout this brochure are typical. Your specific application should not be undertaken without independent study and evaluation for suitability. For specific application recommendations consult Garlock. Failure to select the proper sealing products could result in property damage and/or serious personal injury.

Performance data published in this brochure has been developed from field testing, customer field reports and/or in-house testing.

While the utmost care has been used in compiling this brochure, we assume no responsibility for errors. Specifications subject to change without notice. This edition cancels all previous issues. Subject to change without notice.

GARLOCK is a registered trademark for packings, seals, gaskets, and other products of Garlock.

© Garlock Inc 2003. All rights reserved worldwide.



Garlock Sealing Technologies
1666 Division Street
Palmyra, New York 14522 USA
1-315-597-4811
1-800-448-6688
Fax: 1-800-543-0598
1-315-597-3216

Visit the Garlock network:
www.garlock.net

Other Garlock facilities are located in:

Columbia, SC, USA	1-803-783-1880	Fax: 1-803-783-4279
Houston, TX, USA	1-281-459-7200	Fax: 1-281-458-0502
Sydney, Australia	61-2-9793-2511	Fax: 61-2-9793-2544
São Paulo, Brazil	55-11-884-9680	Fax: 55-11-884-9680
Brantford, Canada	1-519-753-8671	Fax: 1-519-758-2265
Sherbrooke, Canada	1-819-563-8080	Fax: 1-819-563-5620
Jebel Ali, Dubai	971-4-8833652	Fax: 971-4-8833682
West Yorkshire, England	44-1422-313600	Fax: 44-1422-313601
Saint-Étienne, France	33-4-7743-5100	Fax: 33-4-7743-5151
Neuss, Germany	49-2131-3490	Fax: 49-2131-349-222
Mexico City, Mexico	52555-567-7011	Fax: 52555-368-0418
Singapore	65-6285- 9322	Fax: 65-6284-5843